

3D SCANNING

Urban Verbič



Co-funded by
the European Union

Erasmus+

What is 3D scanning?

- **3D scanning** is the process of analyzing a real-world object or environment to collect three-dimensional data of its shape and possibly its appearance (color).
- The collected data can then be used to construct digital 3D models.

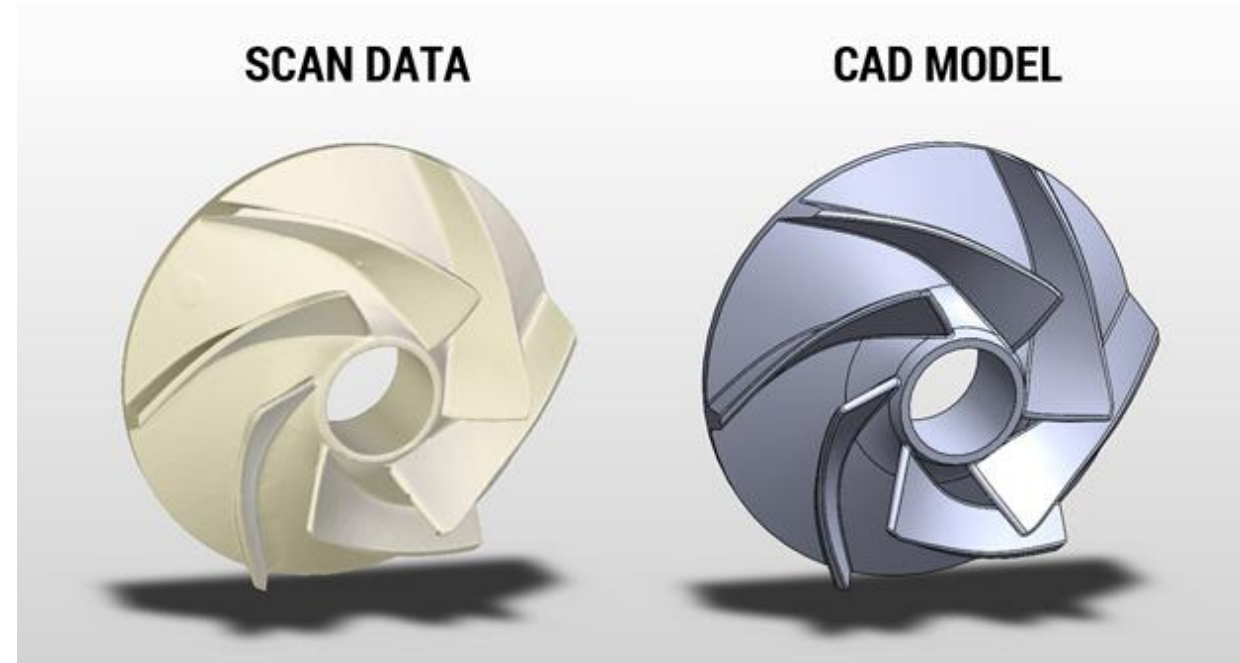

- The result is a 3D file of the object which can be edited and even 3D printed.

What is 3D scanning?

- A **3D scanner** can be based on many different technologies, each with its own limitations, advantages and costs.
- For example, optical technology may encounter many difficulties with dark, shiny, reflective or transparent objects.



What is 3D scanning?

- Collected 3D data is useful for a wide variety of applications.
- These devices are used extensively by the entertainment industry in the production of movies and video games, including virtual reality.



Other applications of this technology include:

- augmented reality,
- motion capture,

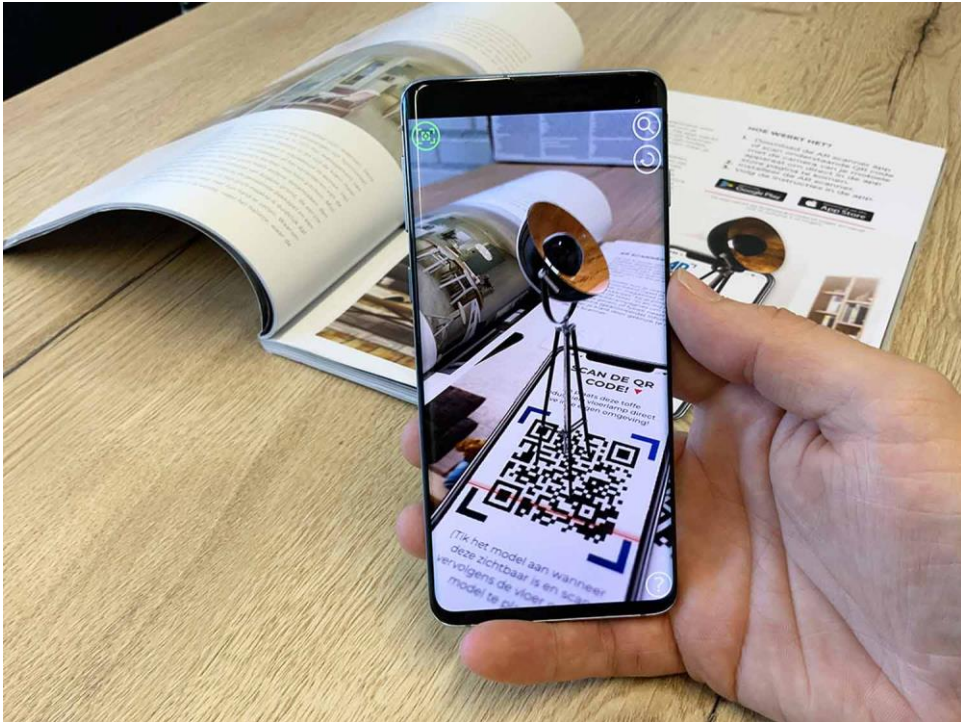

Other applications of this technology include:

- gesture recognition,
- robotic mapping,

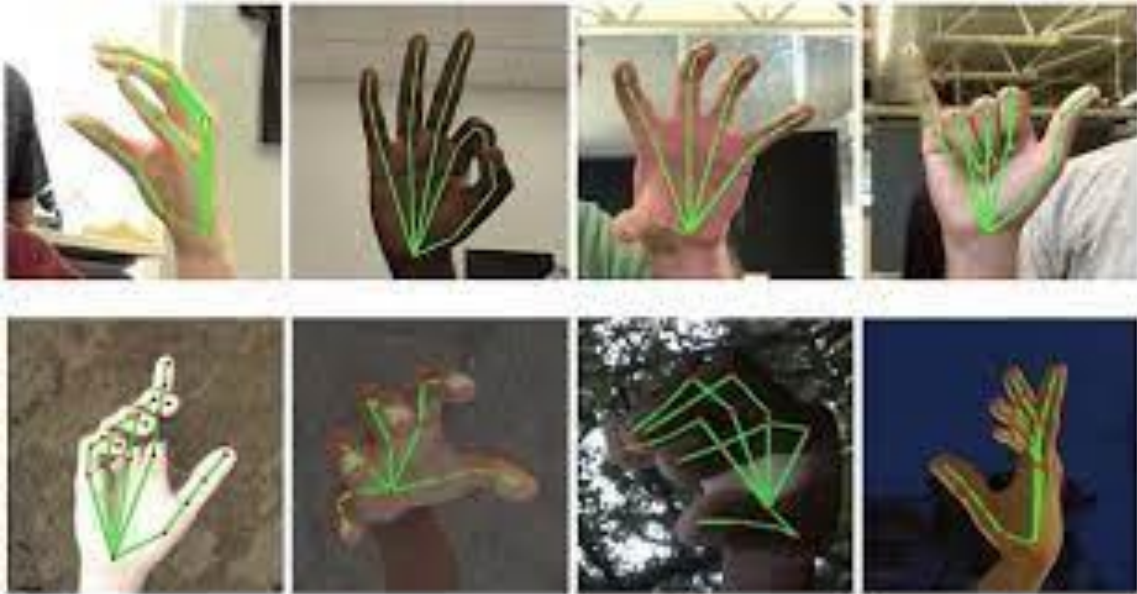

Other applications of this technology include:

- industrial design,
- orthotics and prosthetics

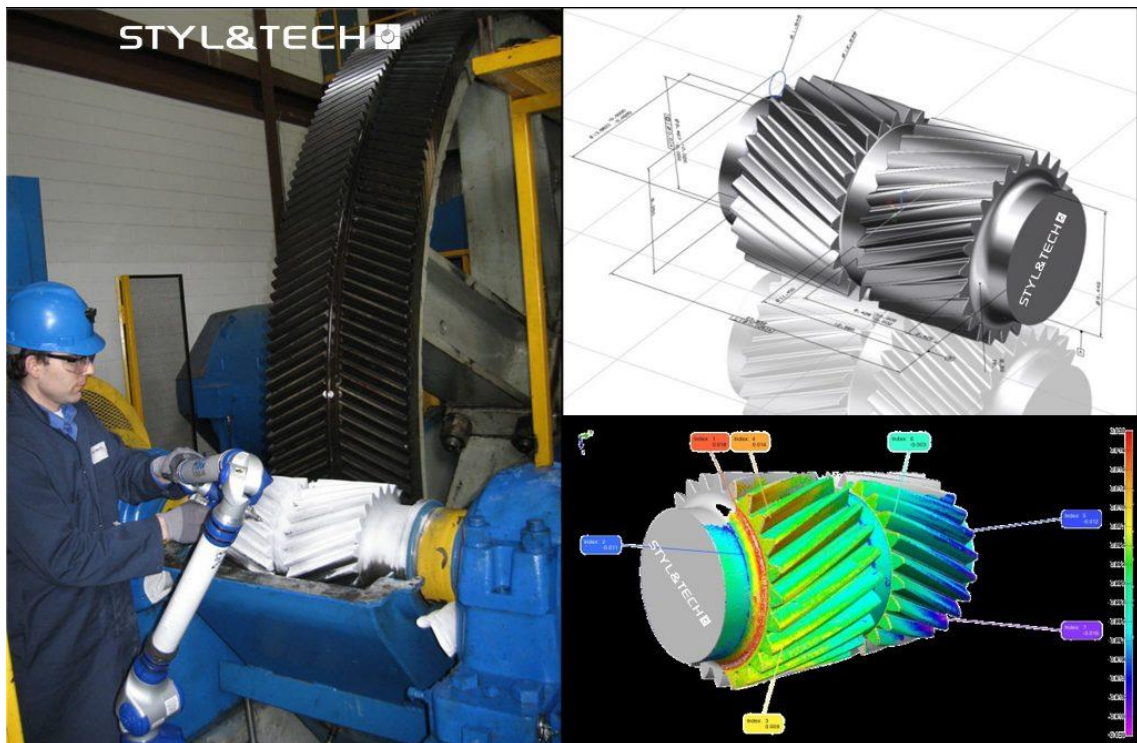

Other applications of this technology include:

- reverse engineering and prototyping,

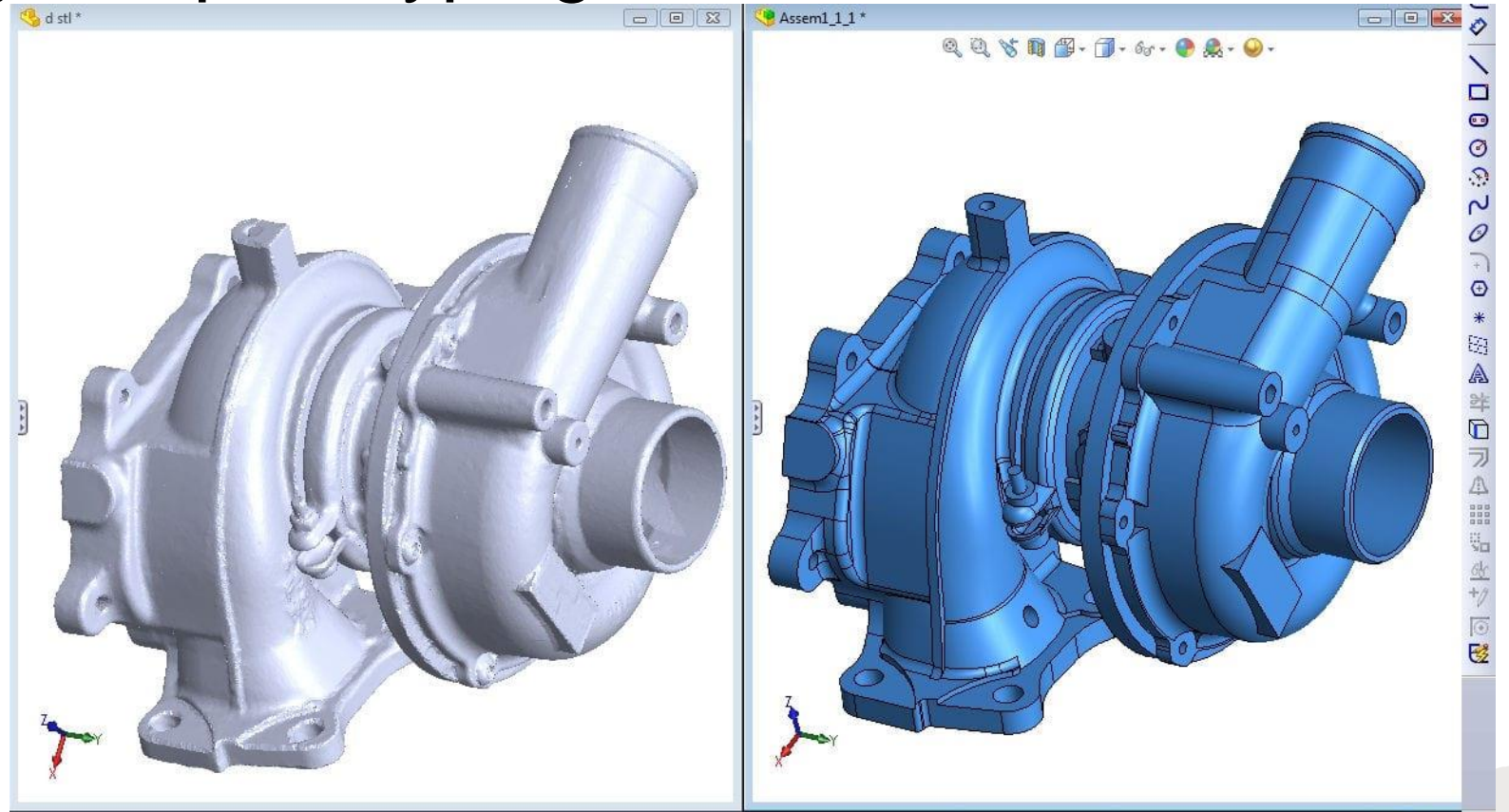

Other applications of this technology include:

- quality control/inspection,



Polygon / mesh Scan

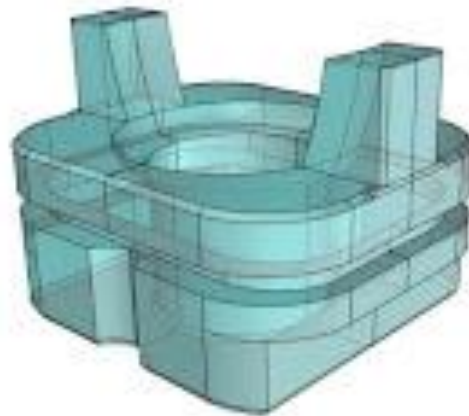

Parametric solid model

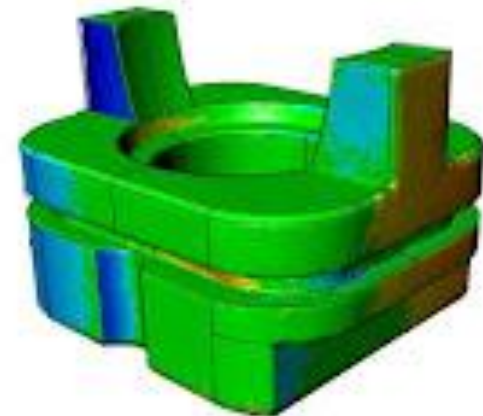

Deviation Analysis Map

Other applications of this technology include:

- digitization of cultural artifacts.



3D scanning technology

There are a variety of technologies for digitally acquiring the shape of a 3D object.

The techniques work with most or all sensor types including:

- seismic

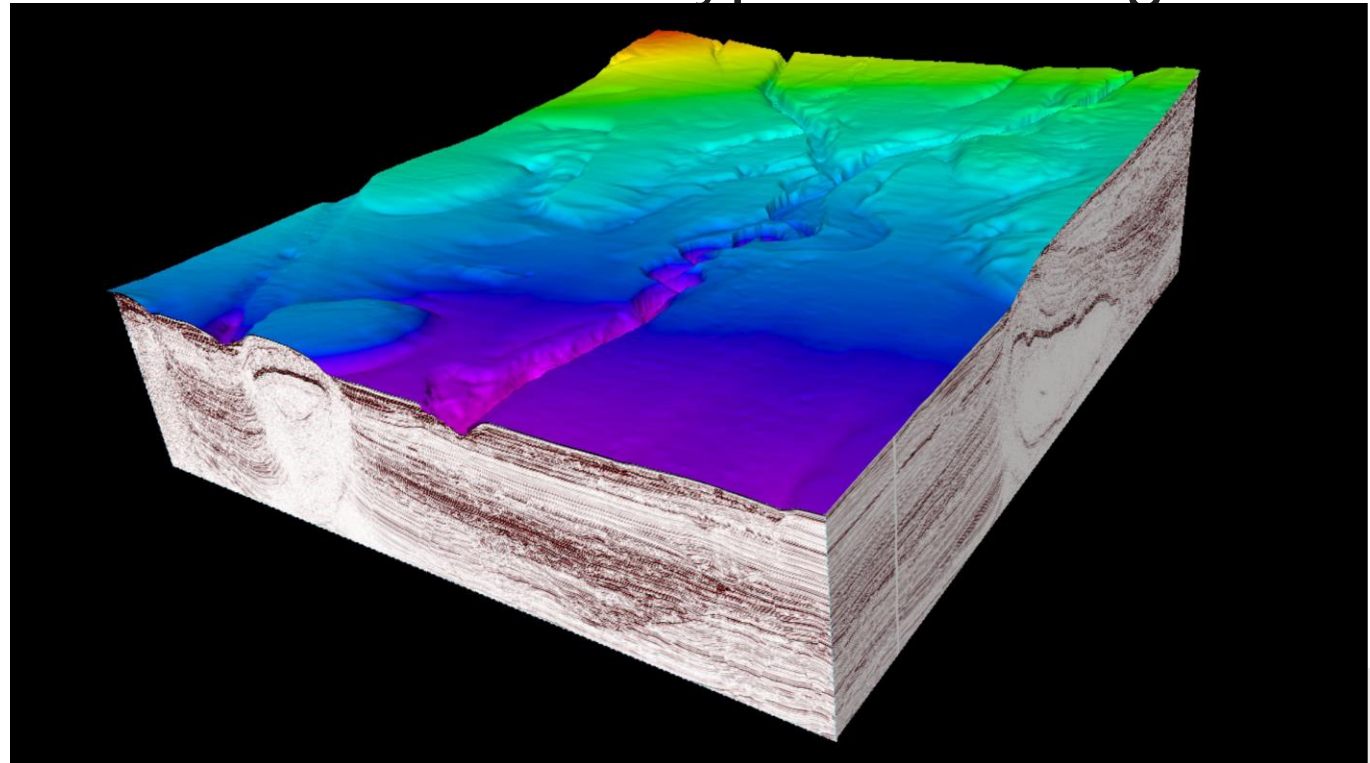

3D scanning technology

The techniques:

- thermal,

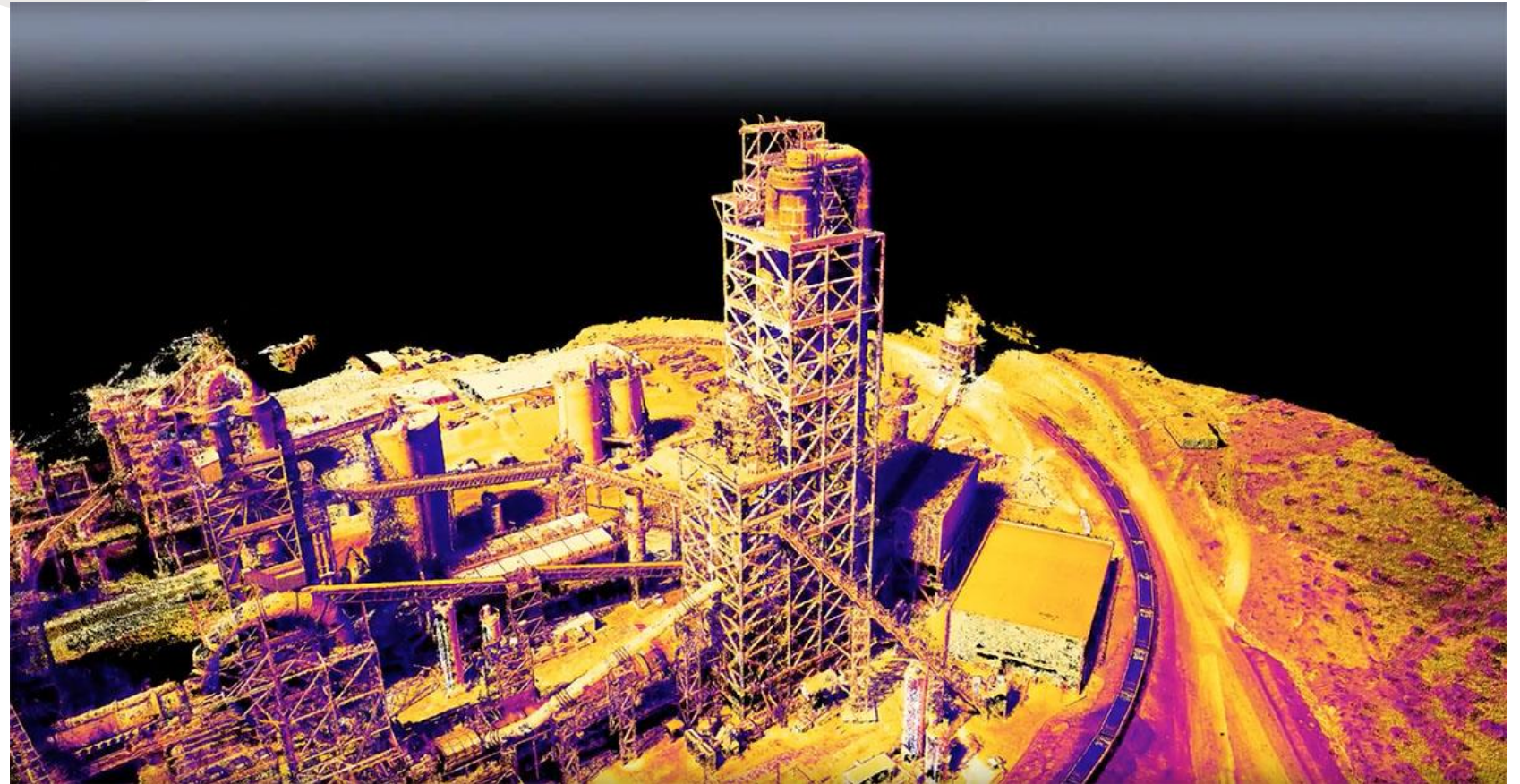

3D scanning technology

The techniques:

- radar,

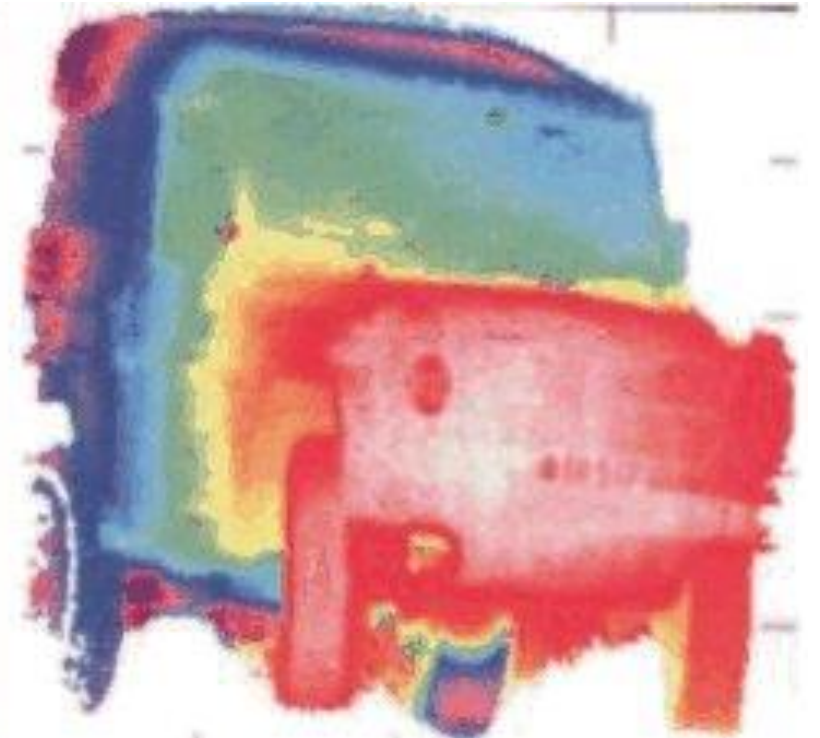
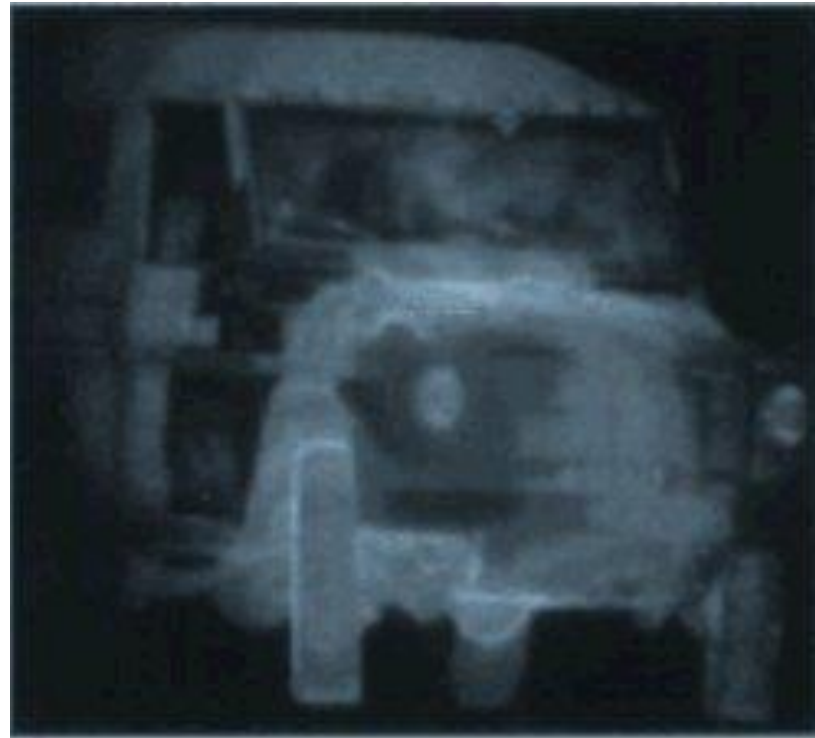

3D scanning technology

The techniques:

- acoustic,

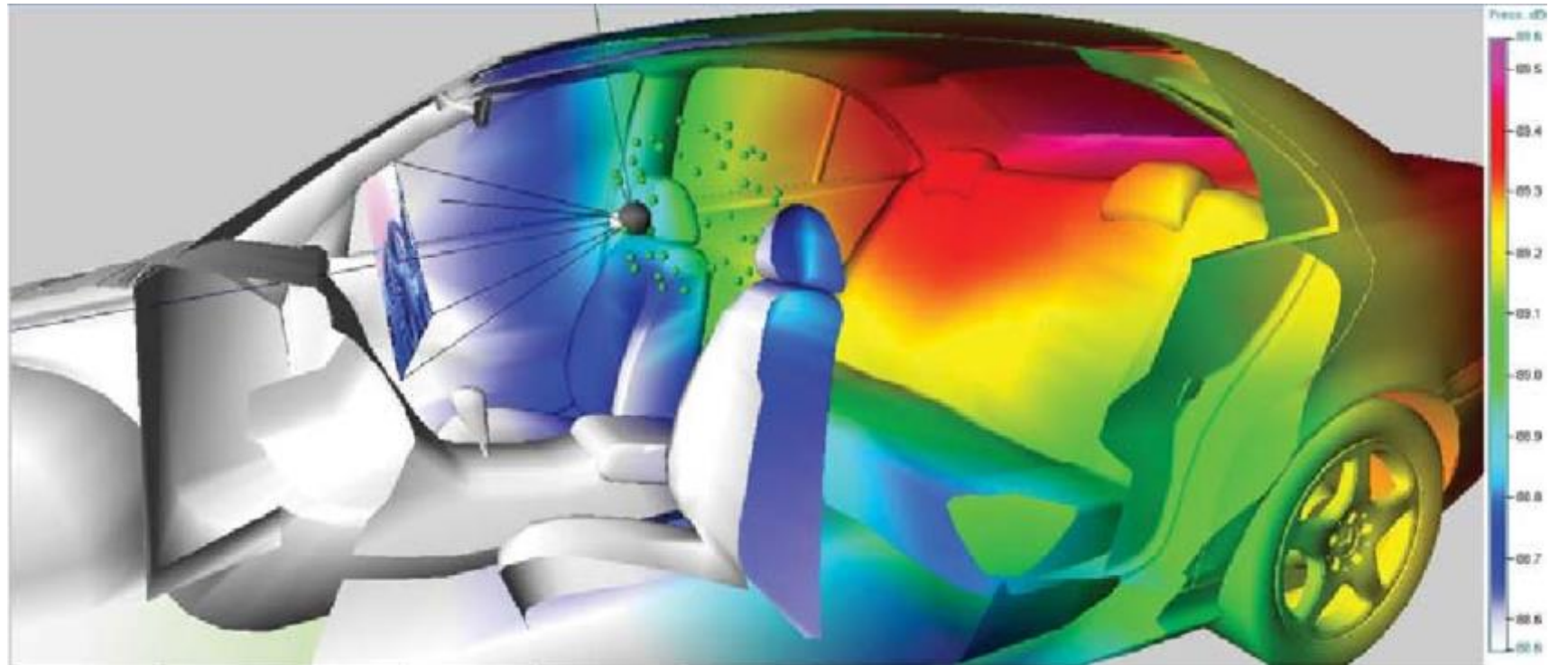

3D scanning technology

The techniques:

- optical,

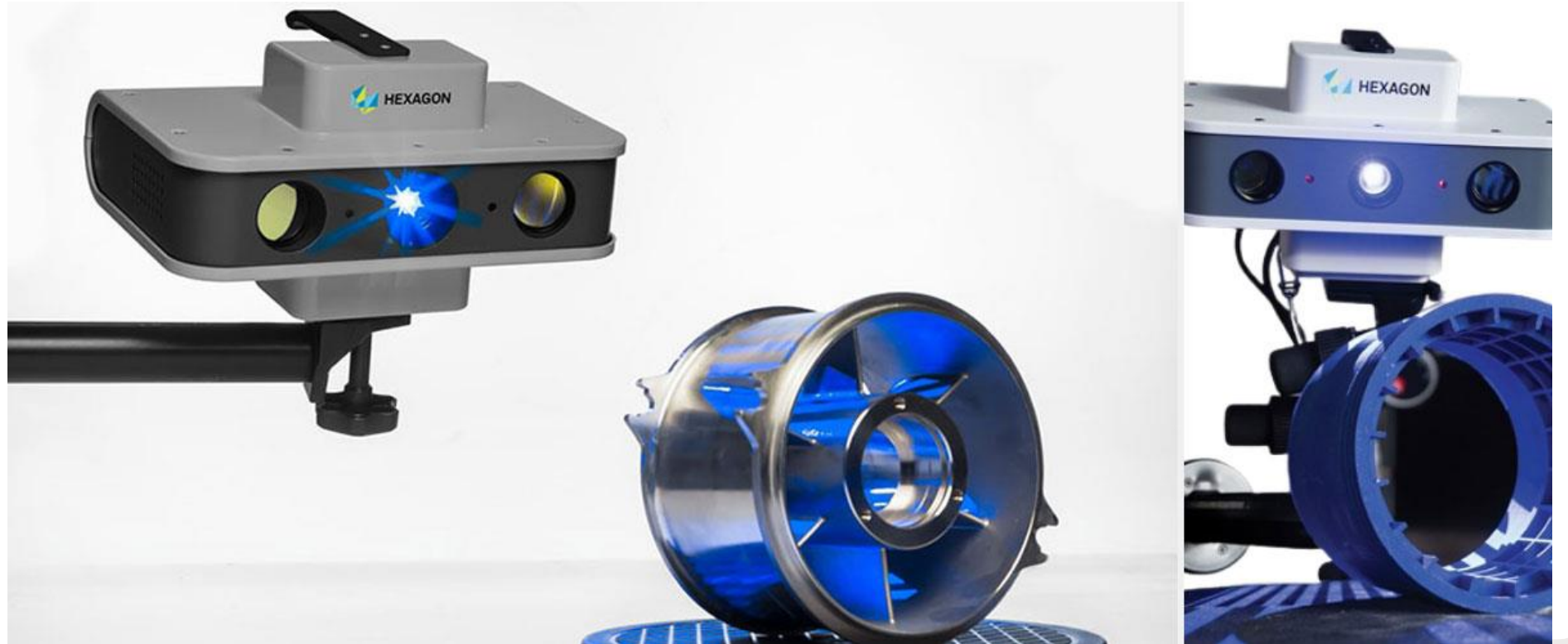

3D scanning technology

The techniques:

- laser scanning,

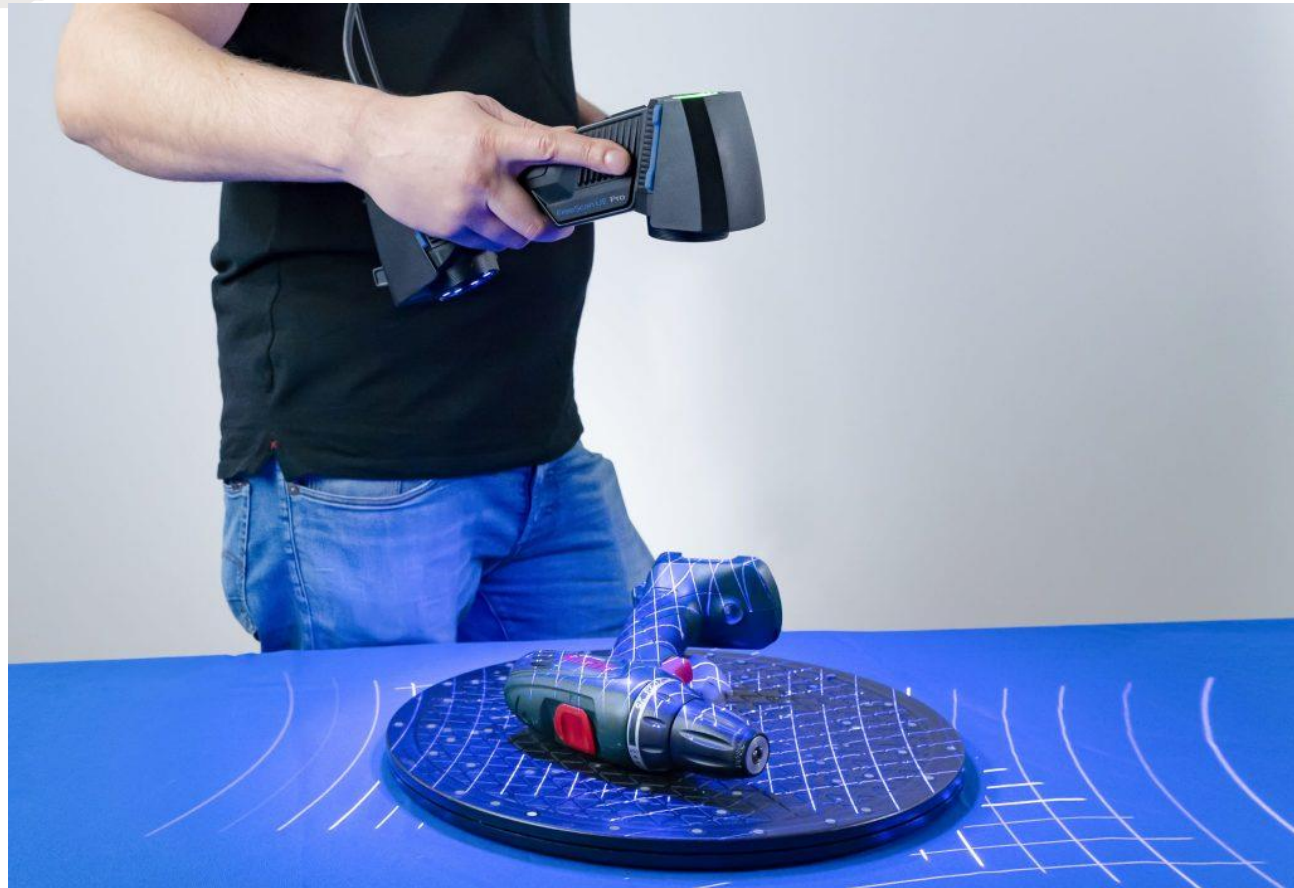

3D scanning technology

A well-established classification divides them into two types:

- contact



- non-contact



3D scanning technology

Non-contact solutions can be further divided into two main categories:

- active
- passive

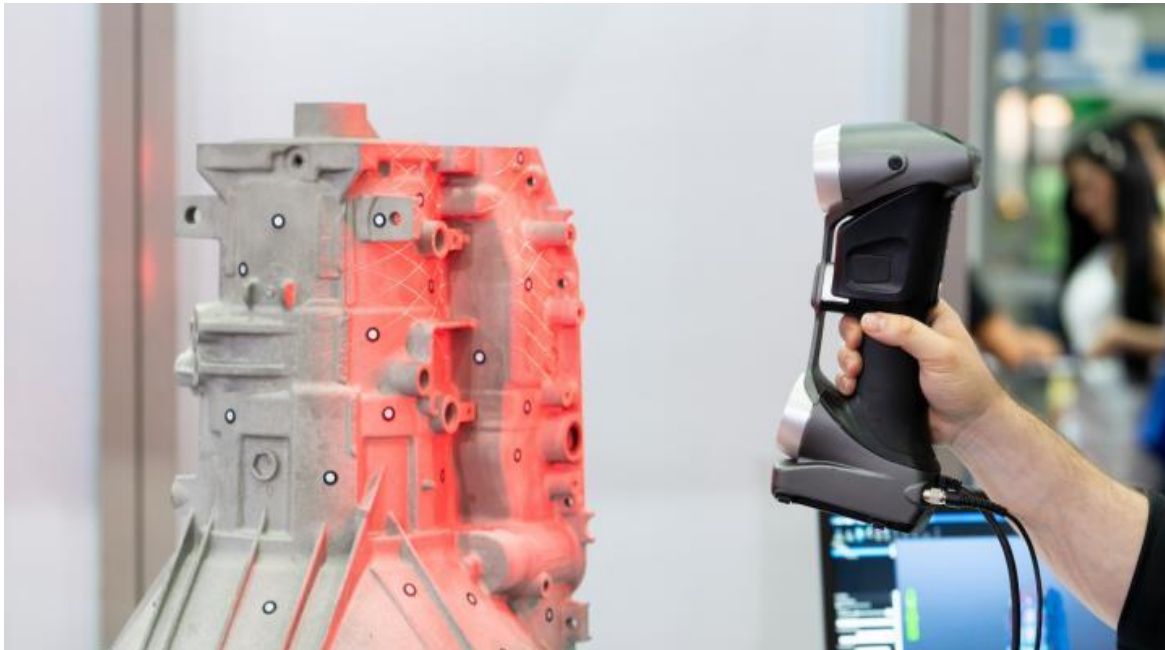

Let's take a closer look at some of the scanners

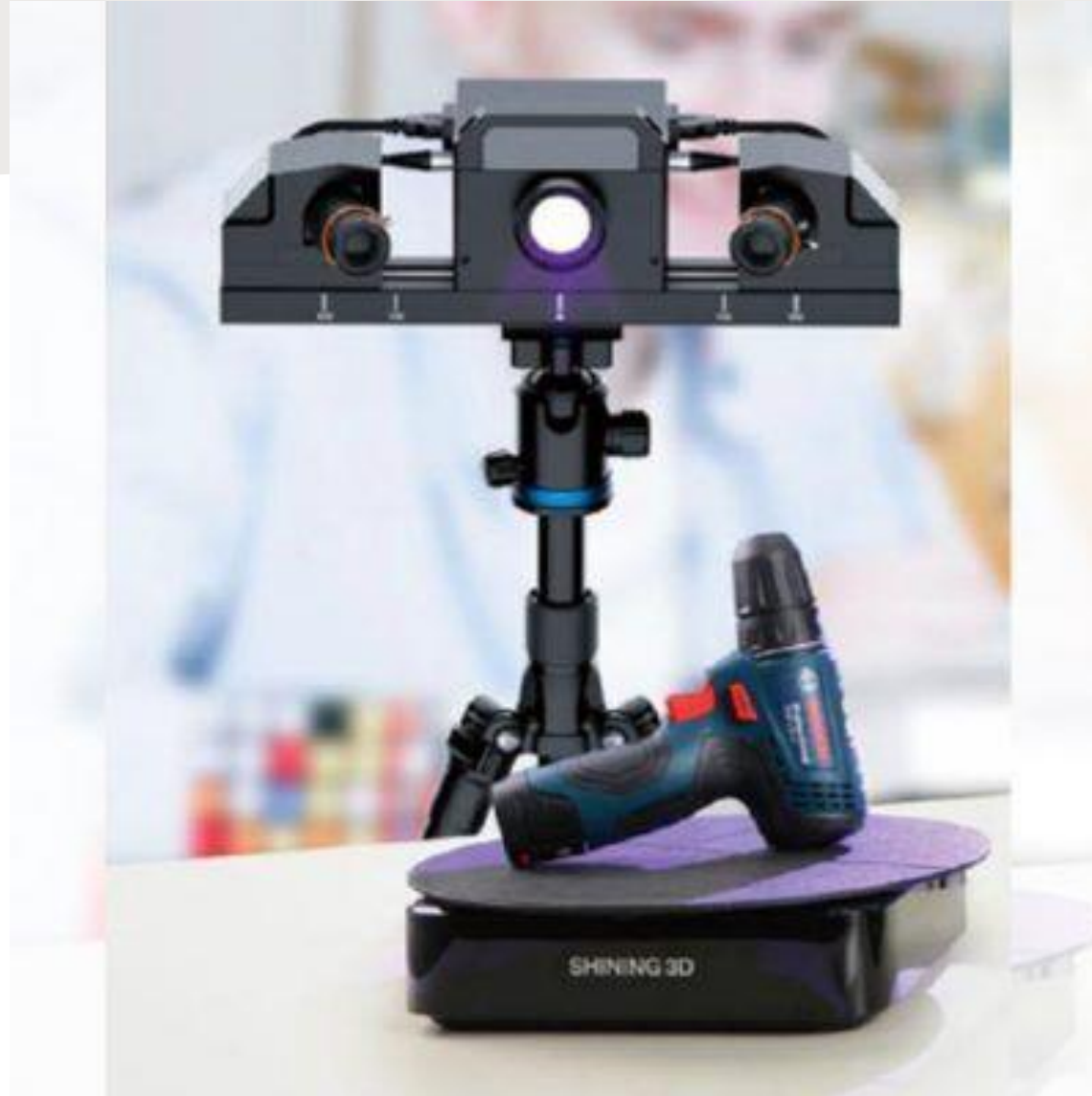

Optical 3D scanner

These scanners work using light patterns that bounce off the surface of an object.

They detect changes in light reflection and create a 3D model based on this.

Optical scanners are widely used in

- industry,
- architecture,
- medicine and
- art.

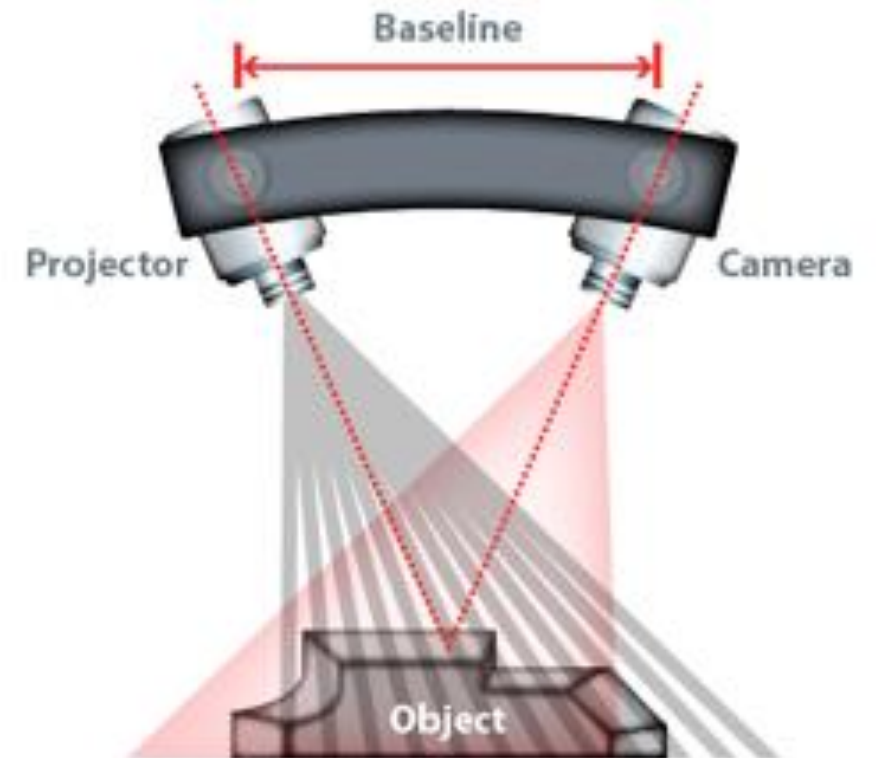

Optical 3D scanner

Pros	Cons
high resolution	sensitivity to light conditions
ability to capture color data	may have problems capturing dark or shiny surfaces
fast data capture	less suitable for capturing data from extremely small or very distant objects.
suitable for capturing small to medium-sized objects.	

Laser 3D scanner

A laser 3D scanner uses a laser beam that moves across the surface of an object.

It measures the time it takes the beam to bounce from the object to the scanner and creates a 3D model based on this data.

Laser scanners are efficient at capturing detailed geometric information and are widely used in:

- mechanical engineering,
- surveying,
- architecture and
- prototyping.

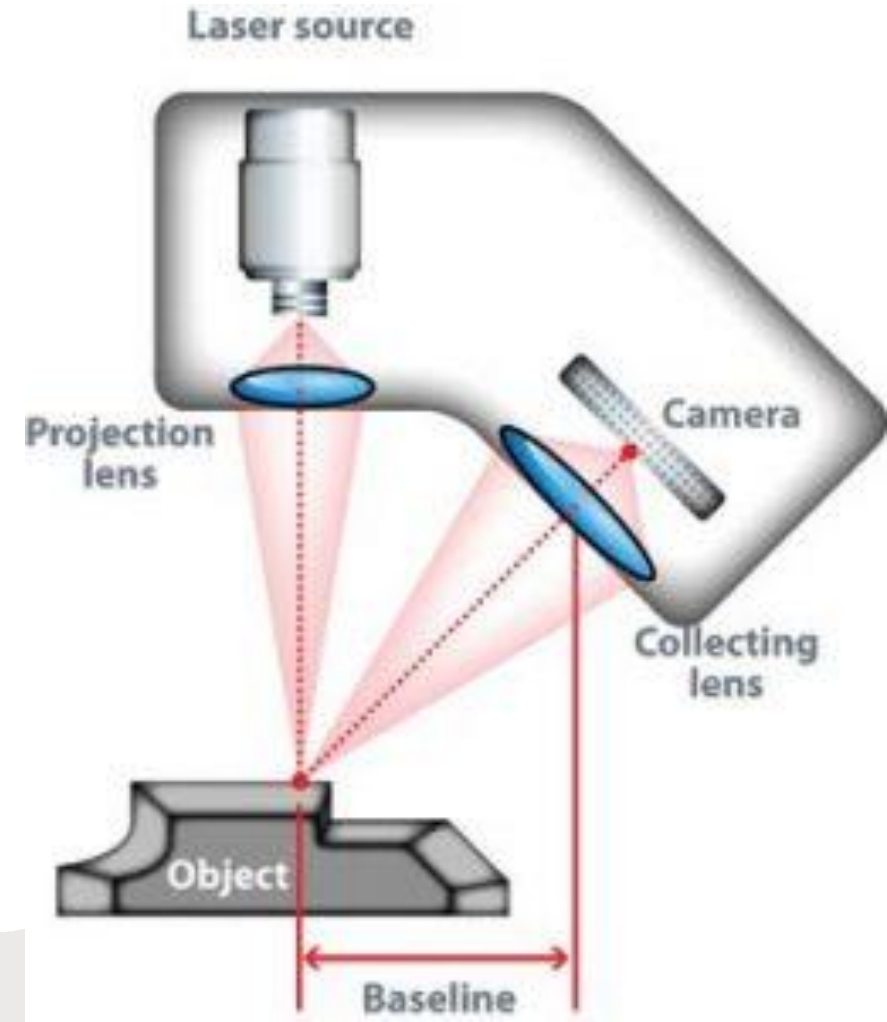

Laser 3D scanner

Pros	Cons
high accuracy of measurements	higher costs
capturing data in real time	sensitivity to changes in the environment
capture of complex geometric data	less suitable for capturing color data.
capture of large objects	

Photogrammetry 3D scanner

This type of scanner uses multiple photographic images of an object from different angles.

Using algorithms for perspective analysis and image processing, a 3D model of the object is created.

Photogrammetric scanners are useful when capturing large objects such as:

- buildings,
- statues and
- landscapes

Photogrammetry 3D scanner

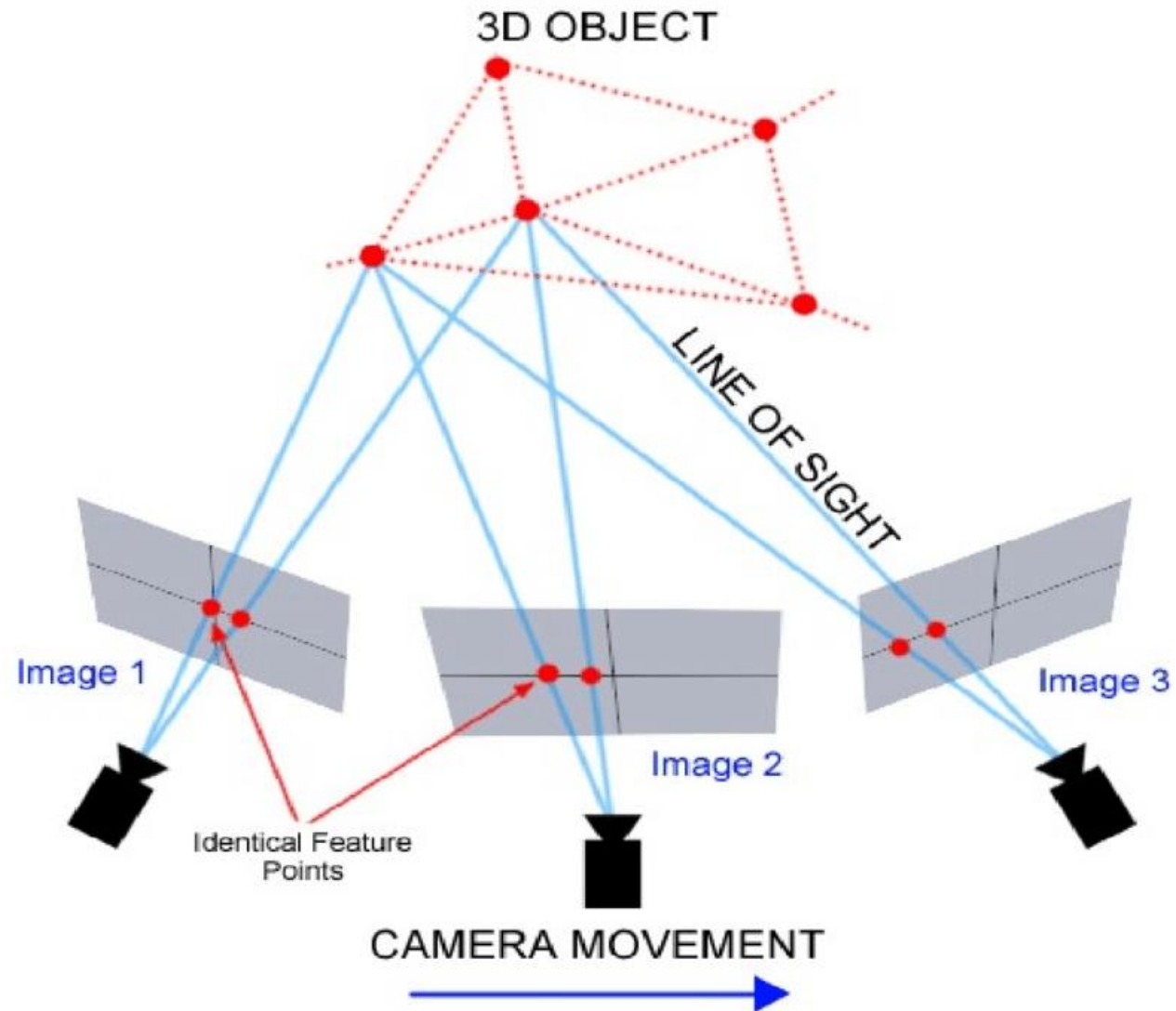

Photogrammetry 3D scanner

Pros	Cons
use of a standard camera	good lighting and contrast are required
simple acquisition of data with the help of several recordings	sensitivity to object or camera movements during capture
suitable for capturing large objects.	less suitable for capturing small details.

Structural light 3D scanner

These scanners project structured light patterns onto the object's surface and use a camera to detect the deformations of these patterns.

Based on these deformations, a 3D model of the object is created.

Structured light scanners are useful for capturing small and medium-sized objects and are widely used in:

- industry,
- archeology and
- computer graphics.

Structural light 3D scanner

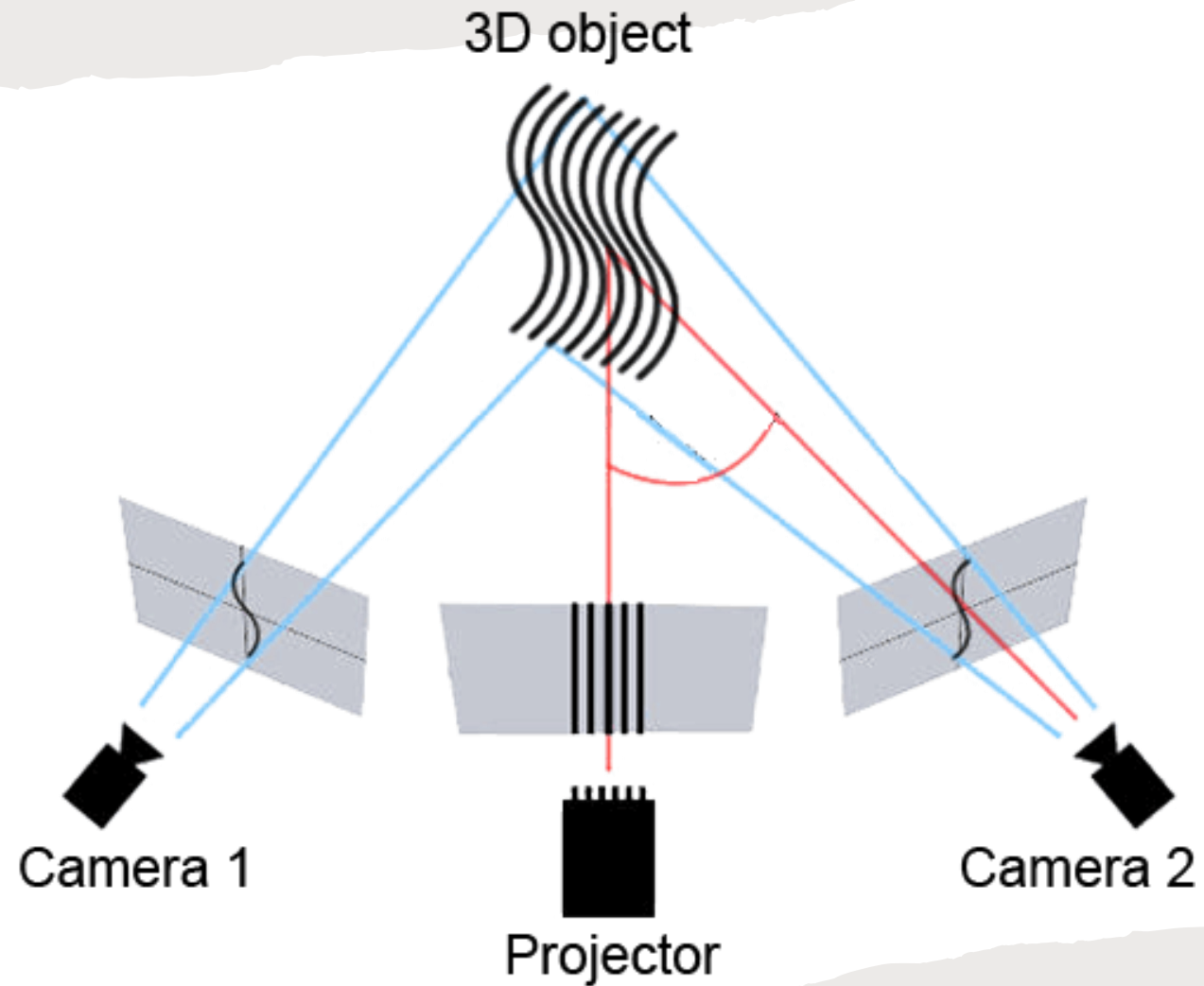

Photogrammetry 3D scanner

Pros	Cons
fast data capture	sensitivity to environmental influences
high accuracy	problems capturing surfaces with specular reflection or folds
the ability to capture data from different angles	additional data processing may be required.
suitable for capturing medium-sized objects.	

Ultrasound 3D scanner

These scanners use ultrasonic waves to measure distances to an object.

Based on the time it takes the ultrasound to bounce from the object to the scanner, a 3D model is created.

Ultrasonic scanners are widely used in:

- medicine,
- materials science and
- surveying.

Photogrammetry 3D scanner

Pros	Cons
work well on objects with soft or elastic surfaces	lower resolution compared to other types of scanners
ability to penetrate through certain materials such as fabrics or plastics.	limited use for certain materials
	sensitivity to sound barriers or reflections

EINSCAN HX 3D SCANNER

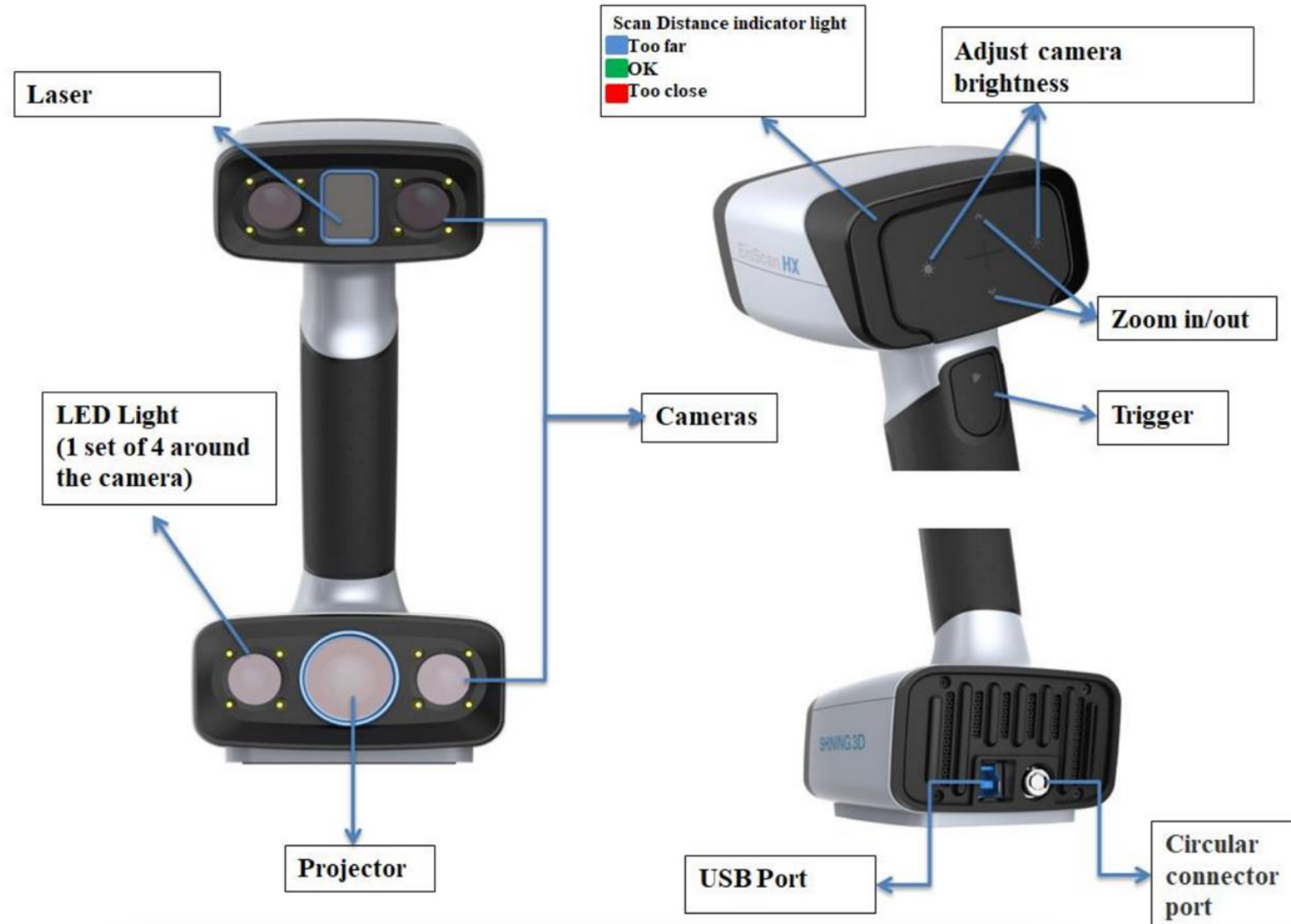

EINSCAN HX 3D SCANNER

	Laser scan	Rapid scan
Part Dimensions	300 mm–4 m	
Light source	Laser	LED
Accuracy	0,04 mm	0,05 mm
Resolution	0,05 mm–3 mm	0,25 mm–3 mm
Alignment	Markers	Markers/geometry/texture/hybrid
Scan speed	50 FPS	15 FPS (no texture), 10 FPS (with texture)
Texture scanning	Not	Yes

3D scanning flow chart

